

$x = FOH + s$							Load Capacity							
							Sideshift 100mm $x = x+17mm$				Standard			
Model		h_3	h_1	h_4	h_2/h_5	α/β	Vulkan & SE		Pneumatic		Vulkan & SE		Pneumatic	
		mm	mm	mm	mm	°	kg @ 500mm	kg @ 600mm	kg @ 500mm	kg @ 600mm	kg @ 500mm	kg @ 600mm	kg @ 500mm	kg @ 600mm
FB18M-2R FB18-2R 6 rollers	FV FOH=325	3330	2210	3973	150	3° / 9°	1800	1600	1800	1600	1800	1600	1800	1600
		3630	2360	4273	150	3° / 9°	1800	1600	1750	1550	1800	1600	1800	1600
		4030	2560	4673	150	3° / 9°	1750	1550	1750	1550	1800	1600	1750	1600
		4530	2810	5173	150	3° / 5°	1700	1500	1600	1450	1750	1550	1650	1500
		5030	3060	5673	150	3° / 5°	1650	1450	1400	1250	1700	1500	1450	1350
	FFV FOH=325	2975	2010	3643	1362	3° / 5°	1800	1600	1800	1600	1800	1600	1800	1600
		3275	2160	3943	1512	3° / 5°	1800	1600	1800	1600	1800	1600	1800	1600
		3575	2310	4243	1662	3° / 5°	1800	1600	1750	1550	1800	1600	1750	1600
		3975	2510	4643	1862	3° / 5°	1750	1550	1750	1550	1800	1600	1750	1600
	TFV FOH=345	4470	2060	5138	1412	3° / 5°	1650	1500			1750	1550		
		4770	2160	5438	1512	3° / 5°	1600	1450			1650	1450		
		5220	2310	5888	1662	3° / 5°	1450	1300			1500	1350		
		5770	2560	6438	1912	3° / 5°	1200	1050			1250	1100		
		6370	2760	7038	2112	3° / 5°	950	850			1000	900		
		6970	2960	7638	2312	3° / 5°	750	650			800	700		
FB20M-2R FB20-2R 6 rollers	FV FOH=335	3350	2260	4046	150	3° / 9°	2000	1800			2000	1800		
		3650	2410	4346	150	3° / 9°	2000	1800			2000	1800		
		4050	2610	4746	150	3° / 9°	2000	1800			2000	1800		
		4550	2860	5246	150	3° / 5°	1900	1700			1950	1750		
		5050	3110	5746	150	3° / 5°	1800	1600			1850	1650		
	FFV FOH=335	2970	2010	3646	1445	3° / 5°	2000	1800			2000	1800		
		3270	2160	3946	1595	3° / 5°	2000	1800			2000	1800		
		3570	2310	4246	1745	3° / 5°	2000	1800			2000	1800		
		3970	2510	4646	1945	3° / 5°	2000	1800			2000	1800		
	TFV FOH=357	4465	2060	5156	1495	3° / 5°	1800	1600			1850	1650		
		4765	2160	5456	1595	3° / 5°	1700	1500			1750	1550		
		5215	2310	5906	1745	3° / 5°	1500	1350			1550	1400		
		5665	2460	6356	1895	3° / 5°	1250	1100			1300	1150		
		6265	2660	6956	2095	3° / 5°	1000	900			1050	950		
		6865	2860	7556	2295	3° / 5°	750	650			800	700		



AM-2R & AE-2R SERIES

1.2 TO 2.0 TON



Choice of controls



Optional Joystick



Wide choice of accessories



Optimal visibility

The AM-2R and AE-2R series of machines are extremely compact, easy to use and require very little maintenance: the ideal partner for the company that is looking for maximum productivity and profitability.

The front axle features two separately excited 4kW electric motors providing a high level of torque for exceptional flexibility when operating in confined areas. Not only do the steering axles ensure precise maneuvering, they also offer the AE-2R trucks superior stability over lengthy drives and reduced curving radius in the AM-2R series.

A pressure switch on the steering wheel operates the power assisted steering.

The logic system with CAN-BUS technology uses a series of sensors and controls to determine and manage the dynamic conditions of the truck, and intervenes if necessary by applying the regenerative emergency brake to prevent the truck from accelerating when curving.

The traction controls can be operated by means of either the lever or the dual pedals, with the choice of the traditional hydraulic proportional lever controls with REED sensors or the comfortable Joystick option with incorporated travel direction control.

On-board comfort is provided by the easy-to-read display with simple functions, the ergonomic layout of the main controls and the standard Grammer MSG20.

In addition to the hour meter and battery state-of-charge indicator, the display also includes a self-diagnosis system of the functions that uses a series of warning lights and codes to inform the operator of any malfunctions or operational errors.

The range of FV, FFV and TFV masts are top-of-the-line in terms of visibility, rigidity

and precision. Lift heights range from 3.3 to almost 7 meters, maintaining high residual capacities when using the side shifter. The 9 kW pump motor ensures rapid lift operations.

The battery compartment is accessed by a series of simple manoeuvres and offers an installed capacity between 300 to 750Ah, particularly in the FB15 (MIG) models in which the battery compartment is high enough to accommodate a 680Ah battery, guaranteeing a perfect mix of agility and durability.

The braking system consists of the following:

- Logic controlled counter-current system operated by releasing the accelerator pedal or reversing
- Hydraulic pedal brake
- Mechanical parking brake

The trucks are very customizable with the following major options available:

- Joystick
- 4 different cab configurations
- Cold stores version
- 4-way hydraulics
- Lighting system
- Different types of tyres
- Integral sideshift

Do not hesitate to contact your nearest Komatsu Forklift dealer; you will be visited by one of our experts who will analyze your requirements and recommend the best solution for you in terms of investment and application.

Please visit our web site

www.komatsuforklift.net to see the complete range of Komatsu Forklift products. You can also register to gain access to the reserved sections of the web site and receive information about new products.

KOMATSU

Part Number: PKSE009EN
Form.No: AM/AE(2R)-S-E-P-11/04

This brochure may contain equipment that are not available in your area. Please consult your Komatsu Forklift distributor for those items you may require. Materials and specifications are subject to change without notice.

Printed in Italy

AM-2R & AE-2R SERIES

1.2 TO 2.0 TON



Electric Three and Four Wheeler Forklift trucks 48 Volt

- Exceptionally easy to handle, use and maintain
- Latest generation MOSFET and CANBUS technology for the greatest reliability and flexibility of movement
- Top quality, proven mechanical and electric part
- Large, ergonomic operator compartment with a high level of comfort
- Masts with excellent visibility and rigidity and optional sideshift for ease of use in all condition
- Standard hydraulic proportional controls and Joystick available as an option

AM-2R & AE-2R SERIES

1.2 TO 2.0 TON

SPECIFICATIONS			FB12M-2R	FB15M-2R	FB15-2R	FB15MG-2R
1.2	Model Designation					
1.3	Motive Power Type					
1.4	Operator Position					
1.5	Rated Capacity	Q (t)	1.2		1.5	
1.6	Load Centre	c (mm)				
1.8	Load Centre, Distance axle centre to fork face	x (mm)			365 ^{3,4}	
1.9	Wheelbase	y (mm)	1152	1260	1280	1260
WEIGHT	2.1 Service Weight (Incl. Battery Weight, Line 6.5)	kg	2620	2875	2852	3047
	2.2 Axle loading (laden) : front/rear	kg	3323 / 497	3842 / 533	3809 / 543	3935 / 612
	2.3 Axle loading (unladen) : front/rear	kg	1222 / 1398	1313 / 1562	1295 / 1557	1406 / 1641
WHEELS	3.1 Tyre Type (P=pneum; S=solid; C=elast. cushion)					
	3.2 Tyre Size, front (dia. x width)					18x7-8 ⁵⁾
	3.3 Tyre Size, rear (dia. x width)					15x4.5-8 ⁵⁾
	3.5 Number of Wheels (x=driven), front/rear					
	3.6 Tread, front	b10 (mm)				932 ⁷⁾
	3.7 Tread, rear	b11 (mm)	2726 ^{3,4)}	2834 ^{3,4)}	2910 ^{3,4)}	2834 ^{3,4)}
BASIC DIMENSIONS	4.1 Mast / Carriage Tilt Angle, forward/backward	°				
	4.2 Mast Height, lowered	h1 (mm)				2210 ¹⁰⁾
	4.3 Free Lift	h2 (mm)				
	4.4 Lift Height	h3 (mm)				3330
	4.5 Mast Raised Height	h4 (mm)			3905 ¹³⁾	
	4.7 Overall Height, Overhead Guard	h6 (mm)		2024		2024
	4.8 Seat Height	h7 (mm)		939		1050
	4.12 Drawbar Height	h10 (mm)				
	4.19 Length to Front Face of Forks	l1 (mm)	2726 ^{3,4)}	2834 ^{3,4)}	2910 ^{3,4)}	2834 ^{3,4)}
	4.20 Overall Length	l2 (mm)	1726 ^{3,4)}	1834 ^{3,4)}	1910 ^{3,4)}	1834 ^{3,4)}
	4.21 Overall Width	b1/b2 (mm)				1067 ⁹⁾
	4.22 Fork Dimensions : thickness/width/length	s/e/l (mm)			40/80/1000	
	4.23 Carriage Class Din 15173 Class A, B					
	4.24 Carriage Width	b3 (mm)				
	4.31 Ground Clearance, Chassis, with Load	m1 (mm)				
	4.32 Ground Clearance at Centre of Wheelbase, with Load	m2 (mm)				
	4.33 Aisle Width with Pallet (1000x1200mm) ^A	Ast (mm)	3052 ^{3,4)}	3160 ^{3,4)}	3325 ^{3,4)}	3160 ^{3,4)}
	4.34 Aisle Width with Pallet (800x1200mm) ^B	Ast (mm)	3176 ^{3,4)}	3284 ^{3,4)}	3525 ^{3,4)}	3284 ^{3,4)}
	4.35 Outer Turning Radius (min.)	Wa (mm)	1361	1469	1760	1469
	4.36 Turning Point to Centre Line of Truck	b13 (mm)	-	-	596	-
PERFORMANCE DATA	5.1 Travel Speed (loaded/unloaded)	km/h				
	5.2 Lifting Speed (loaded/unloaded)	m/s	0.41 / 0.58		0.38 / 0.58	
	5.3 Lowering Speed (loaded/unloaded)	m/s	0.55 / 0.50		0.55 / 0.50	
	5.5 Drawbar Pull (loaded/unloaded) S2 60 min.	N	2390 / 2320	2320 / 2270	2330 / 2280	2300 / 2250
	5.6 Drawbar Pull (loaded/unloaded) S2 5 min.	N	6060 / 5860	6020 / 5810	6030 / 5810	6000 / 5790
	5.7 Gradeability (loaded/unloaded) S2 30 min.	%	7.2 / 10.1	6.1 / 9.0	6.2 / 9.1	5.9 / 8.4
	5.8 Max. Gradeability (loaded/unloaded) S2 5 min.	%	16 / 22.5	13.8 / 20.3	13.9 / 20.5	13.3 / 19.1
	5.9 Acceleration Time over 10 m (loaded/unloaded)	s	4.5 / 4.2			4.6 / 4.2
	5.10 Brake Type (parking/service)					r
E-MOTOR	6.1 Drive Motor, rating S2 60 min. duty cycle	kW				
	6.2 Hydraulic Motor, output S3 15 % duty factor	kW				
	6.3 Battery to DIN 43531/35/36/A,B,C,no					
	6.4 Battery Voltage / Amp. hours	V / Ah	48 / 360 ¹⁰⁾		48 / 480 ¹¹⁾	48 / 480 ¹¹⁾
	6.5 Battery Weight (min.) +/- 5%	kg	590 ¹⁰⁾		780 ¹¹⁾	970 ¹¹⁾
	6.6 Energy Consumption as per VDI Cycle	kWh/h				-
OTHERS	8.1 Type of Control, drive/hydraulic					
	8.2 Auxiliary Hydraulic Pressure for Attachment	bar	154 ⁴⁾			180 ⁴⁾
	8.3 Auxiliary Hydraulic Flow	l/min				
	8.4 Noise Level at Driver's Ear	dB (A)	69	69	69,8	69

A= (l6 x b12); crosswise

B= (l6 x b12); lengthwise

- 1) For alternative tyres see table
- 2) Alternative masts available. See table.
- 3) +17mm with integral sideshift
- 4) +20 mm with TFV (+22mm for 2.0ton)
- 5) For all configurations

- 6) 1.2 ton 183 bar (FFV) - 174 bar (TFV)
1.5 ton 210 bar (FFV) - 200 bar (TFV)
1.8 ton 235 bar (FFV) - 230 bar (TFV)
2.0 ton 220 bar (FFV)- 225 bar (TFV)
- 7) 945 mm with tyres 200/50-10 & 875 mm with tyres 18x5x12 1/8" (Vulkollan)

	FB15G-2R	FB18M-2R	FB18-2R	FB20M-2R	FB20-2R
Battery					
Seated					
500		1.8			2.0
		370 ³⁾⁴⁾			380 ³⁾⁴⁾
1280	1368		1388	1513	1498
3065	3067		3045	3240	3250
3903 / 662	4369 / 498		4337 / 508	4746 / 494	4727 / 523
1389 / 1676	1431 / 1636		1416 / 1629	1582 / 1658	1552 / 1698
SE / SE ¹⁾					
				200/50-10 ¹⁾	
				140/55-9 ¹⁾	
2x / 2				945 ⁹⁾	
2910 ³⁾⁴⁾	2947 ³⁾⁴⁾		3018 ³⁾⁴⁾	3102 ³⁾⁴⁾	3143 ³⁾⁴⁾
3° / 9° ²⁾				2260 ¹⁰⁾	
150				3350	
	3973			4046 ¹⁰⁾	
4			2024		
4			939		
523					
2910 ³⁾⁴⁾	2947 ³⁾⁴⁾		3018 ³⁾⁴⁾	3102 ³⁾⁴⁾	3143 ³⁾⁴⁾
1910 ³⁾⁴⁾	1947 ³⁾⁴⁾		2018 ³⁾⁴⁾	2102 ³⁾⁴⁾	2143 ³⁾⁴⁾
				1150 ¹¹⁾	
			45/100/1000		
2A					
1040 ⁹⁾					
95 ¹⁾					
104					
3325 ³⁾⁴⁾	3268 ³⁾⁴⁾		3443 ³⁾⁴⁾	3427 ³⁾⁴⁾	3578 ³⁾⁴⁾
3525 ³⁾⁴⁾	3392 ³⁾⁴⁾		3643 ³⁾⁴⁾	3552 ³⁾⁴⁾	3778 ³⁾⁴⁾
1760	1577		1878	1722	1998
596	-		646	-	696
14 / 14					
		0.35 / 0.58		0.34 / 0.48	
		0.55 / 0.50		0.45 / 0.39	
2240	2280 / 2240		2290 / 2240	2240 / 2215	
600 / 5780	6020 / 5780		6020 / 5790	5990 / 5776	
5.8 / 8.4	5.4 / 8.3		5.5 / 8.4	5.0 / 7.8	
13.2 / 19.0	12.4 / 18.9		12.5 / 19.0	11.5 / 17.8	
4.2				4.8 / 4.4	
mechanical/hydraulic/electric					
4 x 2					
9					
43531A					
40		48 / 600 ¹²⁾		48 / 750	
		930 ¹²⁾		1055	
				4.7	
MOSFET					
		213 ⁴⁾		207 ⁴⁾	
25					
69,8	69		69,8	69	

8) 1150.5 mm with tyres 200/50-10 & 1002 mm with tyres 18x5x12 1/8" (Vulkolan)
9) With integrated side shift = 980 mm
10) Opt. 300Ah / 549±5%Kg; 345Ah / 580±5%Kg; 375Ah / 590±5%Kg.
11) Opt. 400Ah / 709±5%Kg; 460Ah / 765±5%Kg; 500Ah / 780±5%Kg.
12) Opt. 575Ah / 915±5%Kg; 625Ah / 930±5%Kg.

13) 6 rollers forkcarriage: 3973mm
14) 6 rollers only
15) With freelif + 150 mm

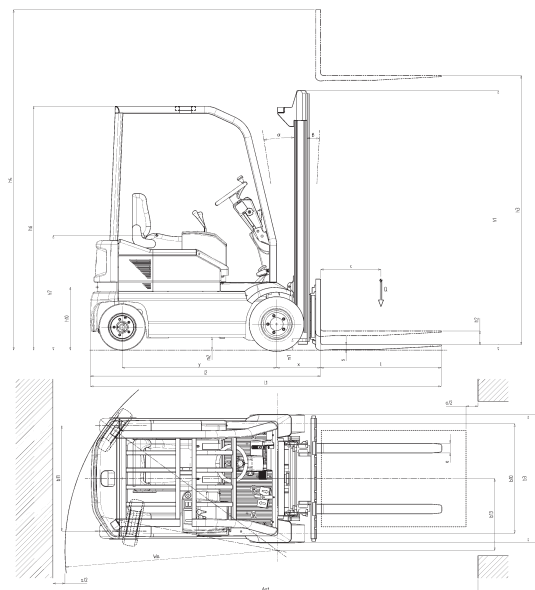
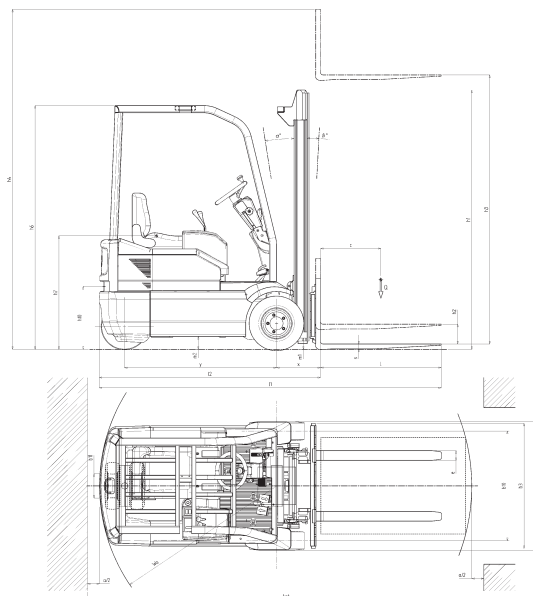

	SE	
	Front	Rear
1.2 & 1.5 ton	18x7-8	15x4.5-8
1.8 ton	18x7-8 (FV&FFV)	15x4.5-8
	200/50-10 (TFV)	15x4.5-8
2.0 ton	200/50-10	140/55-9

	PN	
	Front	Rear
1.2 & 1.5 ton	18x7-8/16	15x4.5-8/12
1.8 ton	18x7-8/16	15x4.5-8/12
2.0 ton	-	-

	Vulkolan / SE	
	Front (Vulkolan)	Rear (SE)
1.2 & 1.5 ton	18x5x12 1/8'	15x4.5-8
1.8 ton	18x5x12 1/8'	15x4.5-8
2.0 ton	18x5x12 1/8'	140/55-9

KOMATSU

WWW.KOMATSUFORKLIFT.NET

x= FOH + s							Load Capacity							
							Sideshift 100mm x = x+17mm				Standard			
							Vulkolan & SE		Pneumatic		Vulkolan & SE		Pneumatic	
Model		h ₃	h ₁	h ₄	h ₂ /h ₅	α/β	kg @ 500mm	kg @ 600mm	kg @ 500mm	kg @ 600mm	kg @ 500mm	kg @ 600mm	kg @ 500mm	kg @ 600mm
		mm	mm	mm	mm	°								
FB12M-2R 4 rollers (*)	FV FOH=390	3330	2210	3905	150	3° / 9°	1200	1050	1200	1050	1200	1050	1200	1050
		3630	2360	4205	150	3° / 9°	1200	1050	1200	1050	1200	1050	1200	1050
		4030	2560	4605	150	3° / 9°	1200	1050	1200	1050	1200	1050	1200	1050
		4530	2810	5105	150	3° / 5°	1200	1050	1100	1050	1200	1050	1150	1050
		5030	3060	5605	150	3° / 5°	1150	1050	1050	1050	1200	1050	1100	1000
	FFV FOH=325	2975	1960	3550	1405	3° / 5°	1200	1050	1200	1050	1200	1050	1200	1050
		3275	2110	3850	1555	3° / 5°	1200	1050	1200	1050	1200	1050	1200	1050
		3575	2260	4150	1705	3° / 5°	1200	1050	1200	1050	1200	1050	1200	1050
		3975	2460	4550	1905	3° / 5°	1200	1050	1200	1050	1200	1050	1200	1050
	TFV FOH=345	4470	2010	5045	1455	3° / 5°	1150	1050			1200	1050		
		4770	2110	5345	1555	3° / 5°	1100	1000			1150	1050		
		5220	2260	5795	1705	3° / 5°	1050	950			1100	1000		
		5770	2510	6345	1955	3° / 5°	900	800			950	850		
		6370	2710	6945	2155	3° / 5°	700	600			750	650		
		6970	2910	7545	2355	3° / 5°	600	550			650	550		
FB15M-2R FB15MG-2R FB15G-2R 6 rollers	FV FOH=325	3330	2210	3905	150	3° / 9°	1500	1350	1500	1350	1500	1350	1500	1350
		3630	2360	4205	150	3° / 9°	1500	1350	1500	1350	1500	1350	1500	1350
		4030	2560	4605	150	3° / 9°	1500	1350	1500	1350	1500	1350	1500	1350
		4530	2810	5105	150	3° / 5°	1450	1300	1400	1250	1500	1350	1450	1300
		5030	3060	5605	150	3° / 5°	1400	1250	1300	1150	1450	1300	1350	1200
	FFV FOH=325	2975	1960	3550	1405	3° / 5°	1500	1350	1500	1350	1500	1350	1500	1350
		3275	2110	3850	1555	3° / 5°	1500	1350	1500	1350	1500	1350	1500	1350
		3575	2260	4150	1705	3° / 5°	1500	1350	1500	1350	1500	1350	1500	1350
		3975	2460	4550	1905	3° / 5°	1500	1350	1500	1350	1500	1350	1500	1350
	TFV FOH=345	4470	2010	5045	1455	3° / 5°	1450	1300			1500	1350		
		4770	2110	5345	1555	3° / 5°	1350	1200			1400	1250		
		5220	2260	5795	1705	3° / 5°	1250	1100			1300	1150		
		5770	2510	6345	1955	3° / 5°	1100	1000			1150	1050		
		6370	2710	6945	2155	3° / 5°	850	750			900	800		
		6970	2910	7545	2355	3° / 5°	650	550			700	600		

(*) 6 rollers optional -> FV h4=h4+68mm FFV&TFV h4=h4+43mm & h2=h2-43mm

